



Instruments for Revision Surgery

Presented by:



CE 0123

WALDEMAR LINK GmbH & Co. KG
Barkhausenweg 10 · 22339 Hamburg, Germany
P.O. Box 63 05 52 · 22315 Hamburg, Germany
Tel.: +49 40 53995-0 · Fax: +49 40 5386929
E-mail: info@linkhh.de · Internet: www.linkhh.de

Instruments for Revision Surgery

| | |
|----|-------------------------------------|
| | Instruments |
| 02 | Instrument Set for Revision Surgery |
| 06 | General Instruments |
| 14 | Additional Instruments |
| | Accessories |
| 26 | Tip Guards |
| 27 | Instrument Systems for Hip Surgery |
| 28 | Index |
| | Important Information |

■ Instrument Set for Revision Surgery

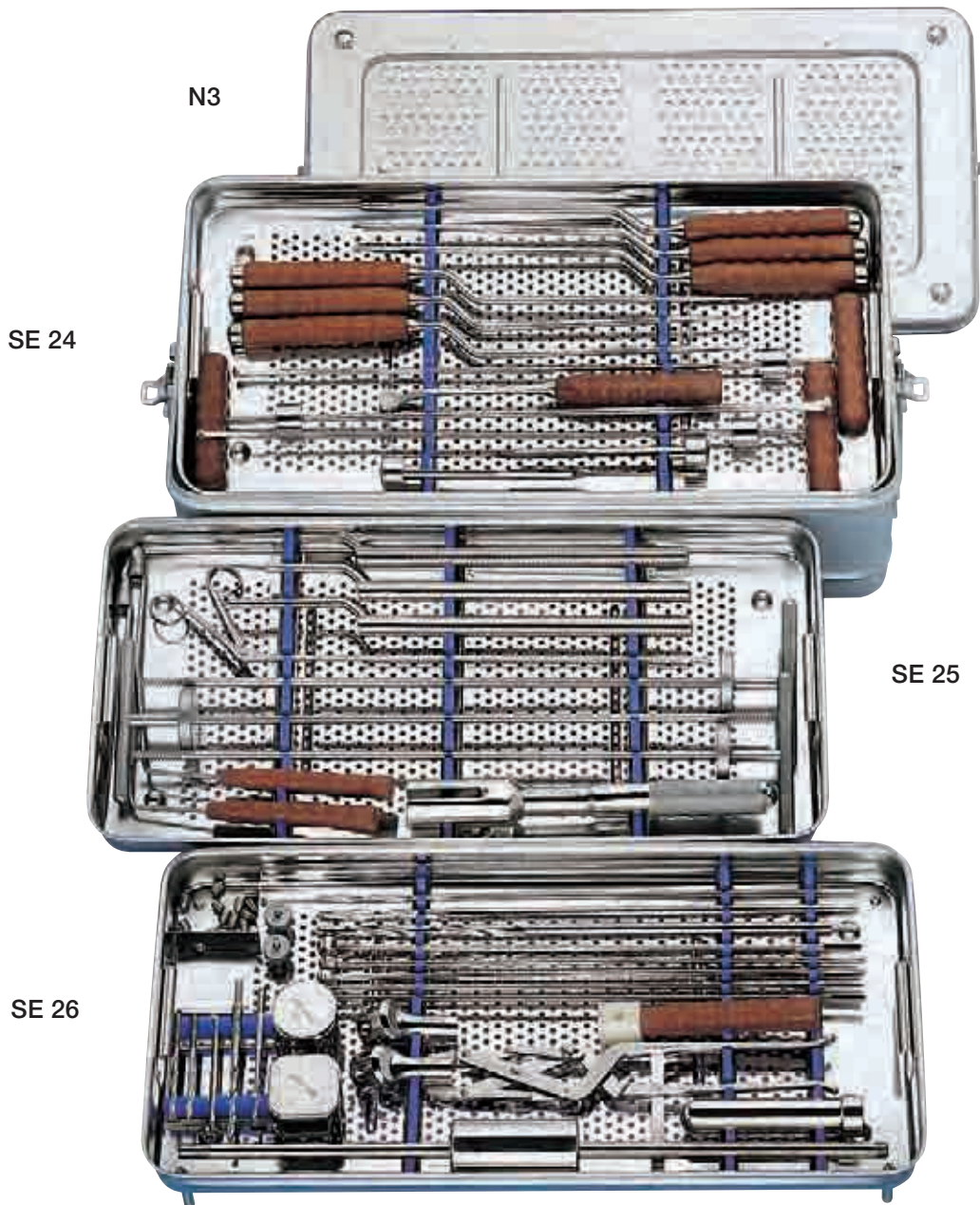

| Item no. | Instrument set for revision surgery |
|----------------------------|--|
| 130-698/01 | Set complete , in stackable container, on three trays with storage inserts |
| 05-2003/01 | N3 stackable container , container lid of stainless steel, container base of molded aluminium, 575 x 275 x 170 mm |
| 130-698/02 | SE 24-N tray , empty, with storage inserts, stainless steel, 550 x 265 x 50 mm |
| 130-698/04 | SE 25-N tray , empty, with storage inserts, stainless steel, 550 x 265 x 50 mm |
| 130-698/06 | SE 26-N tray , empty, with storage inserts, stainless steel, 550 x 265 x 50 mm |

■ Instruments

130-698/02 Tray SE 24

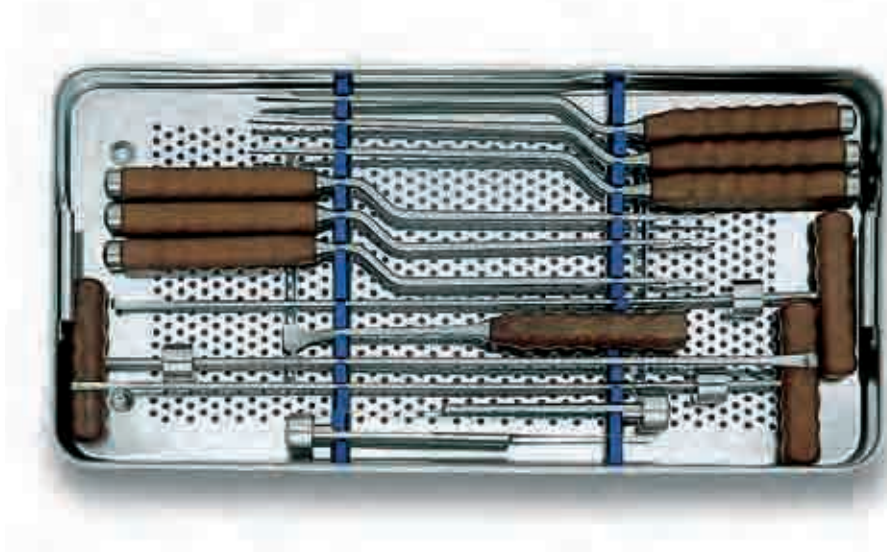

Bone cement chisels, 400 mm

| Item no. | Width mm | Qty. |
|-------------------------|----------|------|
| 130-780 | 5 | 1 |
| 130-781 | 7 | 1 |
| 130-782 | 10 | 1 |

Bone cement gouges, 400 mm

| Item no. | Width mm | Qty. |
|-------------------------|----------|------|
| 130-783 | 5 | 1 |
| 130-784 | 7 | 1 |
| 130-785 | 10 | 1 |

Retrograde cement chisels, 500 mm

| Item no. | Width mm | Qty. |
|-------------------------|----------|------|
| 130-775 | 5 | 1 |
| 130-776 | 7 | 1 |
| 130-777 | 10 | 1 |

| | | |
|-------------------------|--|---|
| 15-1431 | LINK® acetabular cup gouge , 270 mm | 1 |
|-------------------------|--|---|

LINK® osteotomes, 250 mm

| Item no. | Blade width/length mm | Qty. |
|----------------------------|-----------------------|------|
| 65-1701/04 | 4/65 | 1 |
| 65-1701/06 | 6/65 | 1 |

130-698/04 Tray SE 25

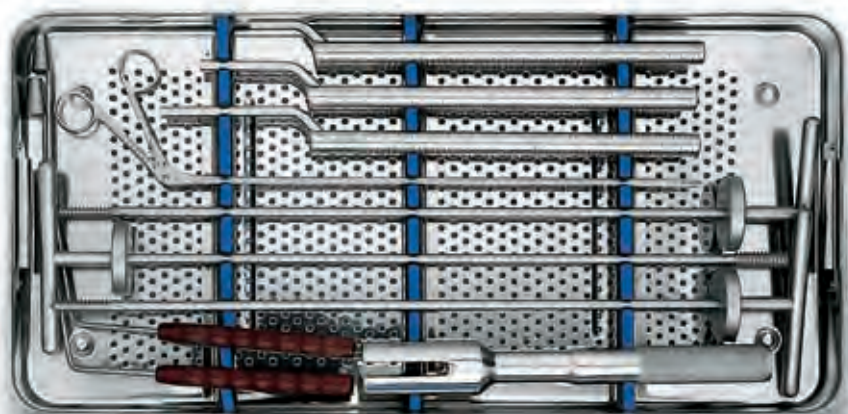

Cement extractor

| Item no. | Ø mm | Qty. |
|-------------------------|------|------|
| 130-680 | 7 | 1 |
| 130-682 | 9 | 1 |
| 130-684 | 11 | 1 |

| | | |
|-------------------------|-------------------------------|---|
| 130-686 | Slotted driver, 270 mm | 1 |
|-------------------------|-------------------------------|---|

| | | |
|-------------------------|--|---|
| 130-744 | Cement grasping forceps, 430 mm | 1 |
|-------------------------|--|---|

Drill guides for twist drill

| Item no. | Ø mm | Qty. |
|-------------------------|------|------|
| 130-676 | 6 | 1 |
| 130-678 | 8 | 1 |

Prosthesis extraction drivers

| Item no. | Length mm | Qty. |
|-------------------------|-----------|------|
| 130-654 | 300 | 1 |
| 130-656 | 330 | 1 |
| 130-658 | 360 | 1 |

■ Instruments

130-698/06 Tray SE 26

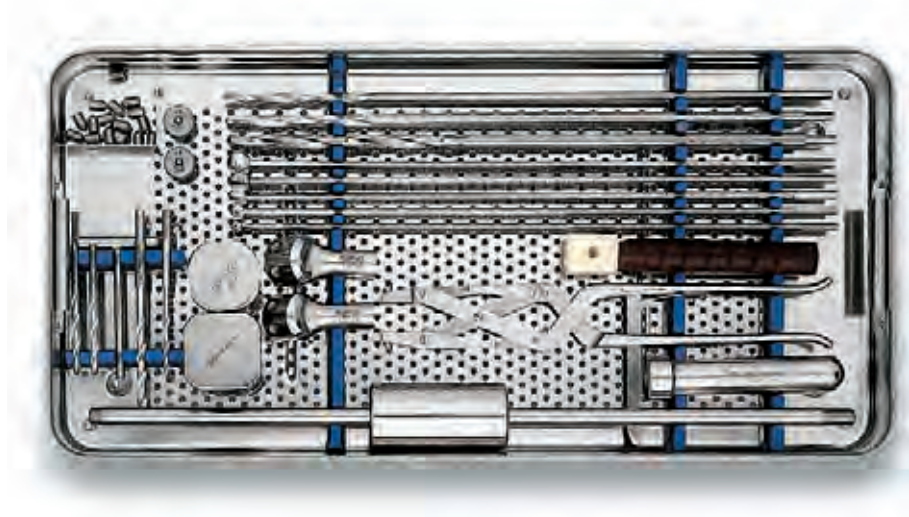

Ball reamers, 400 mm, fittings optional*

| Item no. | Ø mm | Qty. |
|-------------------------|------|------|
| 130-720 | 8 | 1 |
| 130-724 | 10 | 1 |
| 130-728 | 12 | 1 |
| 130-732 | 14 | 1 |
| 130-736 | 16 | 1 |

| | | |
|-------------------------|--|---|
| 15-1137 | Guide handle for ball reamers, 160 mm | 1 |
|-------------------------|--|---|

Twist drills, 400 mm, fittings optional*

| Item no. | Ø mm | Qty. |
|-------------------------|------|------|
| 130-662 | 6 | 1 |
| 130-666 | 8 | 1 |
| 130-670 | 10 | 1 |

Carbide metal twist drills, fittings optional*

| Item no. | Ø x Length mm | Qty. |
|-------------------------|---------------|------|
| 130-642 | 4 x 110 | 1 |
| 130-648 | 6 x 130 | 1 |

| | | |
|----------------------------|---|---|
| 15-1436/01 | Extraction instrument set, complete, for prosthesis with fixed head and for prosthesis stems with taper 12/14 mm or taper 14/16 mm | 1 |
|----------------------------|---|---|

| | | |
|-------------------------|---|---|
| 130-750 | Ewerwahn acetabular cup extraction forceps, 290 mm | 1 |
|-------------------------|---|---|

*How to order: 130-720B = with Hudson fitting

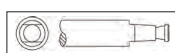

B
Hudson



C
Harris

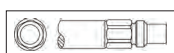

D
AO



E
Jacobs Chuck

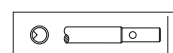

F
Trinkle

■ General Instruments

15-1436/01 Extraction instrument set, complete,
for prostheses with fixed heads and for prosthesis stems with taper 12/14 mm or taper 14/16 mm

consisting of:

15-1436/02 Fitting for prosthesis with integral head Ø 28 to 33 mm (1 ea.)

15-1436/03 Fitting for prosthesis with integral head Ø 35 to 38 mm (1 ea.)

15-1436/04 Fitting for prosthesis stems with taper 12/14 mm (1 ea.)

15-1436/05 Fitting for prosthesis stems with taper 14/16 mm (1 ea.)

15-1436/06 Fixation screws (16 ea.)

15-1436/09 Metal drill bit
Ø 5 mm, length 85 mm (2 ea.)

15-1436/10 Drill guide (2 ea.)

15-1436/11 Hex screw driver
with T-handle for fixation screws (1 ea.)

15-1436/12 Stem (1 ea.)

15-1436/13 Handle (1 ea.)

15-1436/14 Slaphammer (1 ea.)

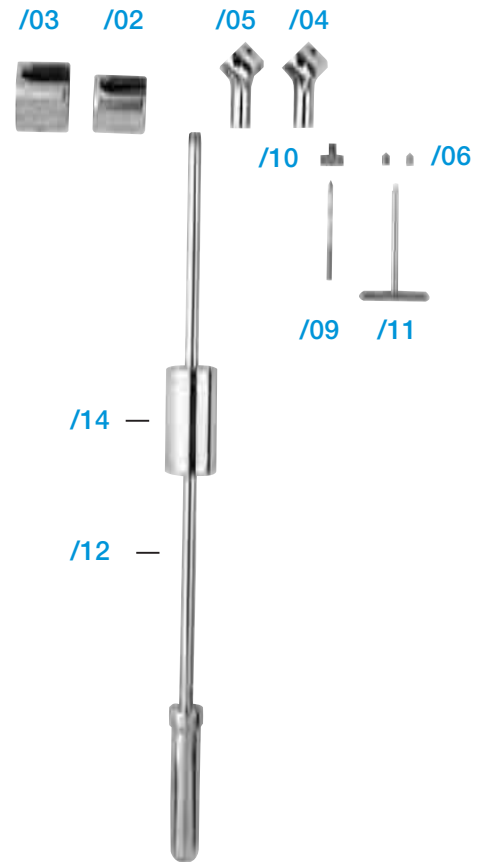

To extract a modular stem the matching cylindrical fitting is placed over the taper. Using a drill guide at least two holes are drilled into the taper. The taper is then connected to the extraction instrument with screws driven into the prepared holes. Hard blows with the slaphammer are usually sufficient to free the modular stem.

The correct fitting is placed over the prosthesis head. The head is then removed, either complete with the stem or alone if the prosthesis is modular, using quick hard blows of the slaphammer.



■ Instruments

Carbide metal twist drills

with widia cutting edges, fittings optional*

| Item no. | Length mm | Ø mm |
|----------|-----------|------|
| 130-642 | 110 | 4 |
| 130-648 | 130 | 6 |

* Please specify fitting: see page 05

These drills can be used to drill a hole into the prosthesis stem as a target for chiseling once a bone fenestration has been created.



99-0001/99 Zabel Revision Instrument

For removal of a distal prosthesis fragment.

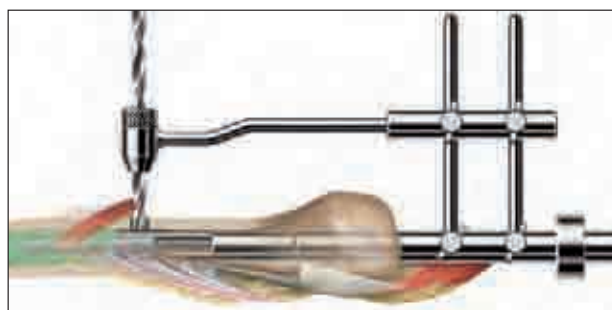
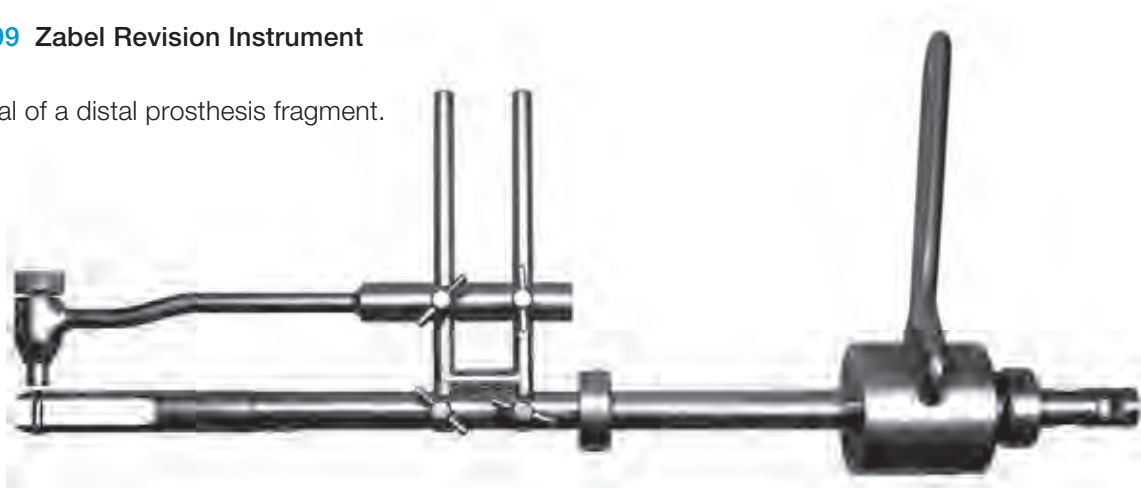

Complete perforation of the fragment without drill gauge. Sliding on of the load arm of the extraction instrument. Insertion of the metal screw.

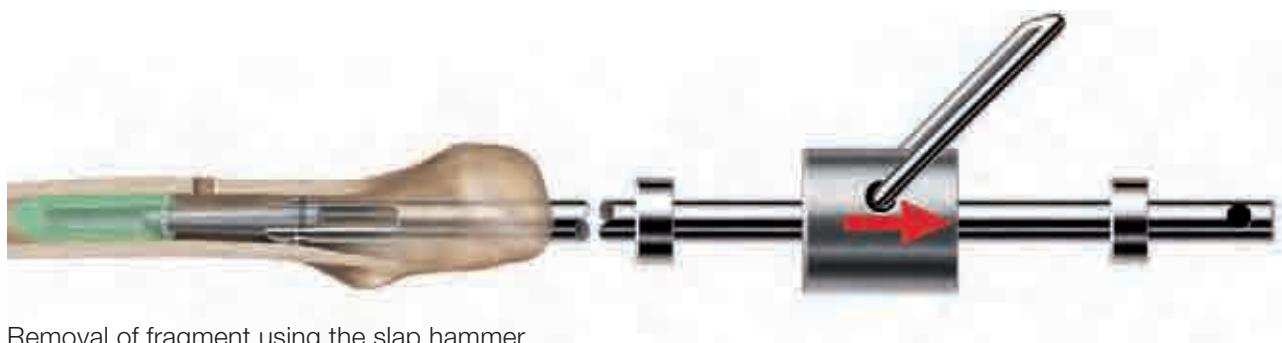
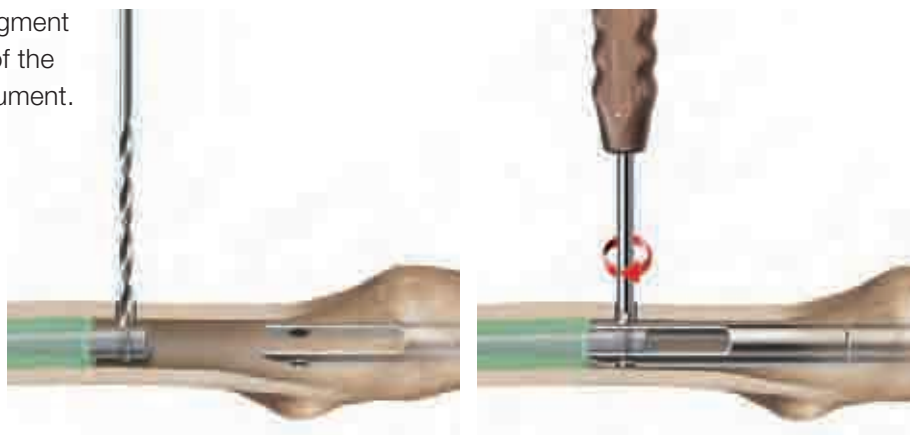

Removal of fragment using the slap hammer.

Using the drill gauge to drill a hole in the proximal end of the fragment.



■ Instruments

Prosthesis extraction drivers,
bayonet-shaped, 8 mm diameter

| Item no. | Tip length mm | Overall mm |
|----------------|---------------|------------|
| 130-654 | 30 | 300 |
| 130-656 | 60 | 330 |
| 130-658 | 90 | 360 |

Prosthesis extraction drivers are designed to remove femoral prostheses through a window made in the femur at a point distal to the stem. The driver with the shortest tip is used first, followed by those with medium and long tips in this sequence.

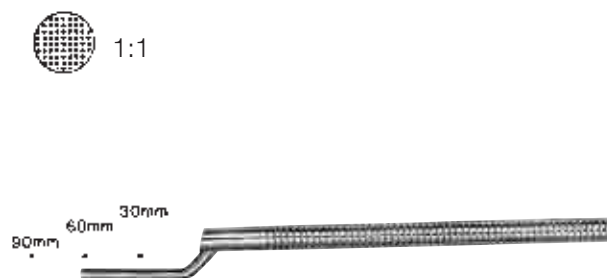

Twist drills, 400 mm, fittings optional*

| Item no. | Ø mm |
|----------------|------|
| 130-662 | 6 |
| 130-666 | 8 |
| 130-670 | 10 |

* Please specify fitting: see page 05

These long twist drills are especially well suited for drilling a central guide hole in distal cement sections.



The drill guide centers the drill in the femoral cavity. It is especially suitable for drilling into sloping cement surfaces.



Drill guides with handle for twist drill

| Item no. | Twist drill Ø mm |
|----------------|------------------|
| 130-676 | 6 |
| 130-678 | 8 |

The drill guide ensures that the twist drill remains centralized when drilling into the cement base.

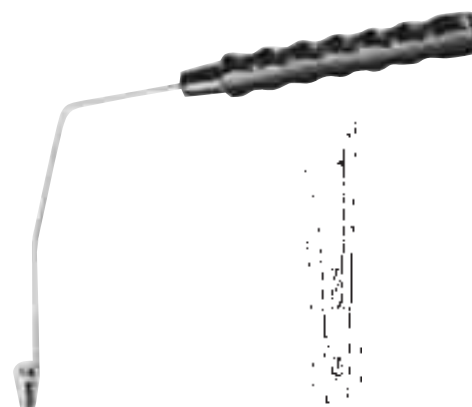

Cement extractor

with T-Handle and driving plate, used with slotted driver 130-686

| Item no. | Ø mm | Twist drill Ø mm |
|----------------|------|------------------|
| 130-680 | 7 | 6 |
| 130-682 | 9 | 8 |
| 130-684 | 11 | 10 |



After drilling a centered hole in the cement, the corresponding cement extractor is screwed in. The cement block is then removed with short, hard taps. Either the slotted driver or the special mallet (15-1170) is used depending on the situation.



130-686 Slotted driver

for cement extractor and retrograde cement chisel, 270 mm



130-744 Cement grasping forceps

working length 350 mm, overall length 430 mm



The flat, slim jaws of these forceps make them particularly effective in reaching and removing residual bone cement particles.



■ Instruments

Bone cement chisels,

bayonet-shaped, osteotome bevelled, 400 mm

| Item no. | Width mm |
|----------|----------|
| 130-780 | 5 |
| 130-781 | 7 |
| 130-782 | 10 |

The bayonet-shaped shafts of these chisels allow the surgeon a better overall view of the operating area during removal of bone cement from the medullary canal. The metal shaft runs all the way through the linen phenolic handle. Hitting the end thus ensures the direct transmission of impact to the cement.

Bone cement gouges,

with internal bevel, bayonet-shaped, 400 mm

| Item no. | Width mm |
|----------|----------|
| 130-783 | 5 |
| 130-784 | 7 |
| 130-785 | 10 |

The gouges have an internal bevel. This ensures that the chisel blade remains at the junction between cement and bone and does not drift into the middle of the medullary cavity.

Retrograde cement chisels, 500 mm

| Item no. | Width mm |
|----------|----------|
| 130-775 | 5 |
| 130-776 | 7 |
| 130-777 | 10 |

Retrograde cement chisels are designed for scraping residual cement from the walls of the medullary cavity using brief, sharp blows of the slotted hammer to the driving plate. The handle at their end enables the surgeon to guide the chisel with ease and precision.

Tip guards

to protect cutting edges see page 26.

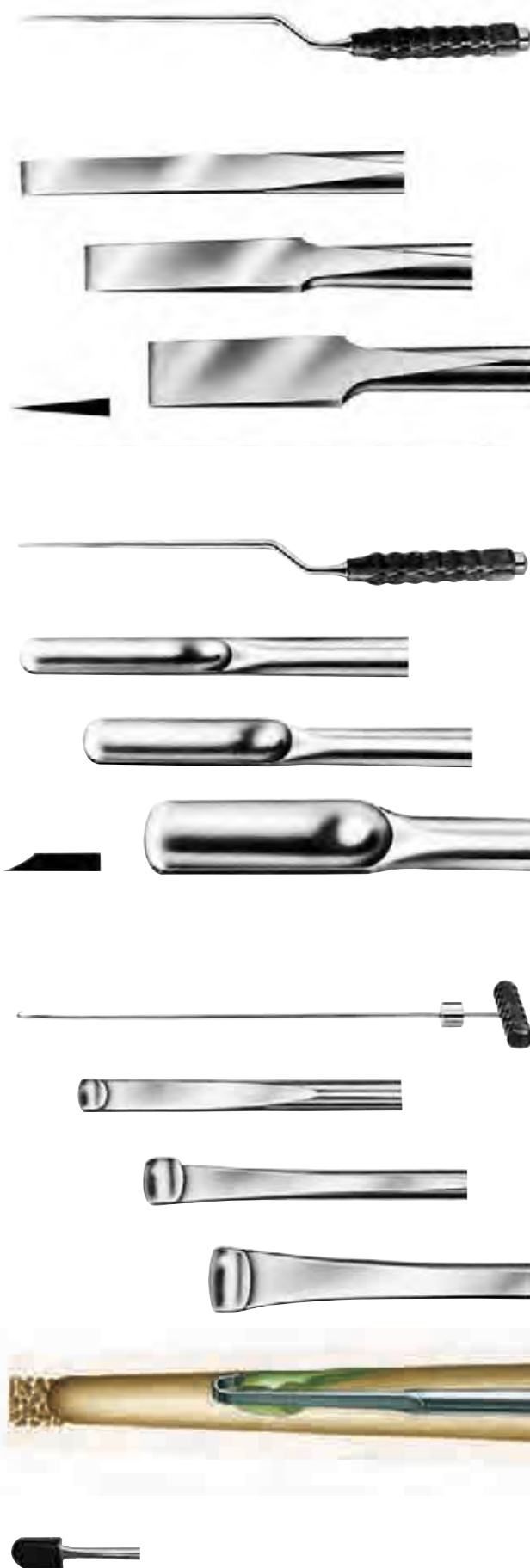

15-1431 Acetabular cup gouge

bayonet-shaped, set-off,
width 20 mm, length 270 mm

The acetabular cup gouge is specially shaped to facilitate removal of cement-fixed acetabular components.



Osteotomes, 250 mm

| Item no. | Blade width mm | Working length mm |
|------------|-------------------|----------------------|
| 65-1701/04 | 4 | 65 |
| 65-1701/06 | 6 | 65 |

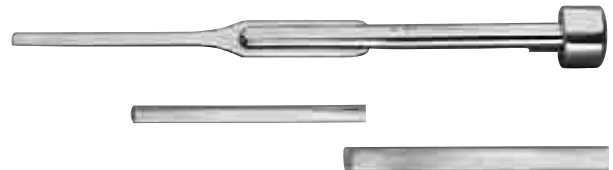

The thin-bladed osteotomes are particularly suitable for revision operations because of their razor-type blade with which it is possible to cut the bone/cement border deep inside the femoral canal.



■ Instruments

Ball reamers, 400 mm, fittings optional*

| Item no. | Ø mm |
|----------------|------|
| 130-720 | 8 |
| 130-724 | 10 |
| 130-728 | 12 |
| 130-732 | 14 |
| 130-736 | 16 |

* Please specify fitting: see page 05

The extra long ball reamers may be used to ream cement layers and to remove cement islands in the distal femoral cavity.

Reaming of the cement mantle with a set of extra long ball reamers. The surgeon must be able to see into the femoral canal during reaming.



15-1137 Guide handle

for long ball reamers 130-720 to 130-736,
160 mm, plastic and linen phenolic

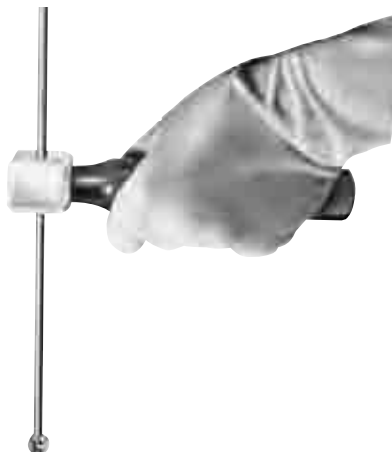

■ Additional Instruments

130-750 Ewerwahn acetabular cup extraction forceps with parallel action jaws and lock, hand forged, 290 mm

The jaws of these forceps are equipped with sharp external pins to firmly grip the internal wall of the acetabular cup to be extracted. The long arms provide excellent leverage so that even firmly cemented cups can be loosened.

Reference: Ewerwahn, W. J. (1975) Extraktionszange für Kunststoff-Hüftpfannen. Der Chirurg 46, 574



Bone cement chisels*, straight, 310 mm

| Item no. | Width mm |
|----------------|----------|
| 130-690 | 5 |
| 130-692 | 7 |
| 130-694 | 10 |



Bone cement chisels*, bayonet-shaped, 400 mm, single-sided bevel

| Item no. | Width mm |
|-------------------|----------|
| 15-1440/05 | 5 |
| 15-1440/07 | 7 |
| 15-1440/10 | 10 |



*not included in instrument set

■ Additional Instruments

Bone cement gouges*,

bevelled outer edge, straight, 310 mm

| Item no. | Width mm |
|----------|----------|
| 130-700 | 5 |
| 130-702 | 7 |
| 130-704 | 10 |



Gouges with a bevelled inner edge are entially used to cut between bone and cement. They are not suitable for leverage and may deviate into the bone.

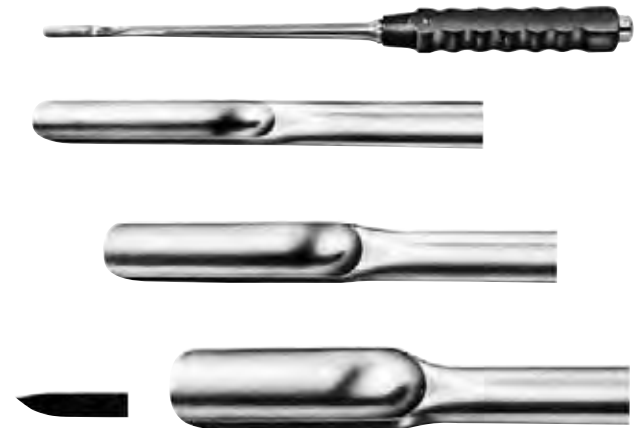

Gouges with a bevelled outer edge are more difficult to use than those with an internal bevel but they allow leverage and deviate less easily into the bone.

Bone cement gouges*,

bevelled inner edge, straight, 310 mm

| Item no. | Width mm |
|----------|----------|
| 130-710 | 5 |
| 130-712 | 7 |
| 130-714 | 10 |

For removing cement block and/or residual cement during revision.



Tip guards

to protect cutting edges see page 26.



Sheathed osteotomes*, 250 mm

| Item no. | Width mm | Working length mm |
|------------|----------|-------------------|
| 65-1700/04 | 4 | 65 |
| 65-1700/06 | 6 | 65 |
| 65-1700/20 | 20 | 65 |
| 65-1700/25 | 25 | 65 |

Replacement blades*, only

| Item no. | Width mm |
|------------|----------|
| 65-1702/04 | 4 |
| 65-1702/06 | 6 |
| 65-1702/20 | 20 |
| 65-1702/25 | 25 |

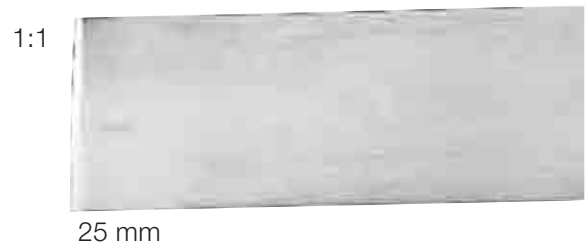
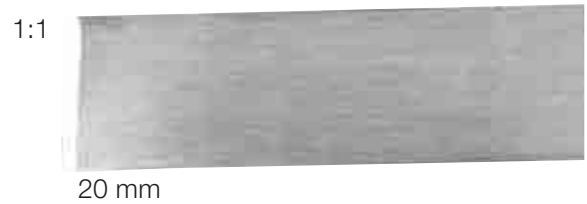

The thin-bladed sheathed osteotomes are recommended where fenestration of the femur is necessary to allow stem removal. The area of the fenestration is marked with drill holes prior to osteotomy.

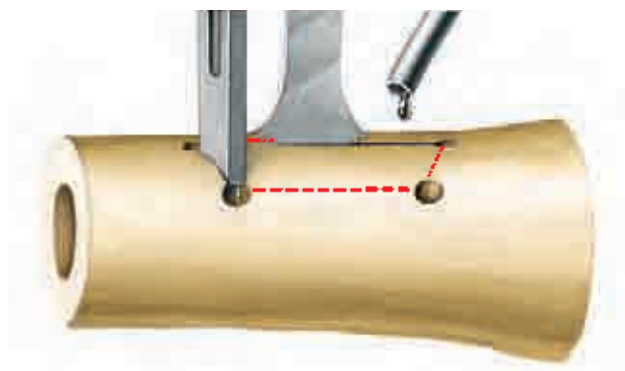
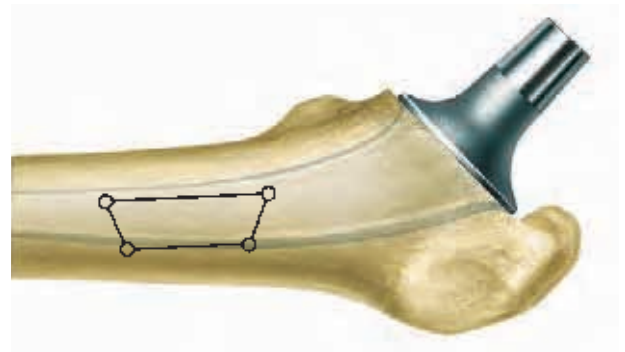

*not included in instrument set

■ Additional Instruments

Bone cement splitting chisels*, straight, 310 mm

| Item no. | Width mm |
|------------|----------|
| 130-787/05 | 5 |
| 130-787/10 | 10 |

After the stem has been extracted the bone cement splitting chisel is used to cut the cement mantle radially into individual segments which are easily removable.



Bone cement splitting chisels*, bayonet-shaped, 400 mm

| Item no. | Width mm |
|------------|----------|
| 130-786/05 | 5 |
| 130-786/10 | 10 |

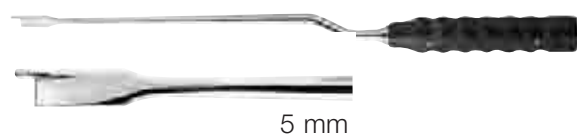

Diamond-coated cement rasps*, 520 mm

| Item no. | Diamond rasp |
|------------|----------------|
| 130-788/01 | flat curve |
| 130-788/02 | acute curve |
| 130-788/03 | slight V-shape |

The rasps enable the surgeon to remove small cement islands remaining in the medullary cavity leaving a slightly rough surface for future implantation.



Gouges*, with bevelled inner edge and distally angled shaft, 400 mm

| Item no. | Width mm |
|-------------------|----------|
| 130-796/05 | 5 |
| 130-796/07 | 7 |
| 130-796/10 | 10 |



The bevelled inner edge enables these gouges to cut extremely thin cement slivers.



Gouges*, with bevelled inner edge and distally angled bayonet shaped shaft, 400 mm

| Item no. | Width mm |
|-------------------|----------|
| 130-797/05 | 5 |
| 130-797/07 | 7 |
| 130-797/10 | 10 |



These gouges are used for removal of bone cement which is not visible from the proximal end of the bone. They are inserted through a stem fenestration.



*not included in instrument set

■ Additional Instruments

130-790 Fiber-optic light tip*

with clips for mounting onto bayonet-shaped chisels and gouges 130-780 to 130-785

The Fiber-optic light tip provides excellent illumination of the medullary cavity during the operation.

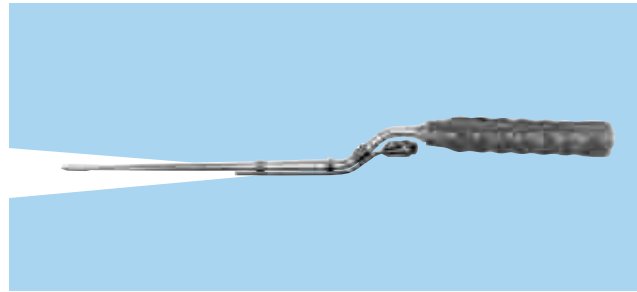

130-795 Fiber-optic light cable*,

extra long, Ø 3.5 mm, 250 cm
(not illustrated)

Suction lamp*, 250 mm

| Item no. | Ø mm |
|----------|------|
| 130-794 | 6 |

For suction of fluids from the medullary cavity. Fiber-optic light fibers are arranged around the edge of the suction tube to aid vision when working on deep sections of the medullary cavity.



15-1150 Probe*,

flexible and graduated, 385 mm

To probe the femoral cavity for a possible perforations.



The flexible probe is especially suitable for locating cortical defects. The graduations make it possible to estimate distances.

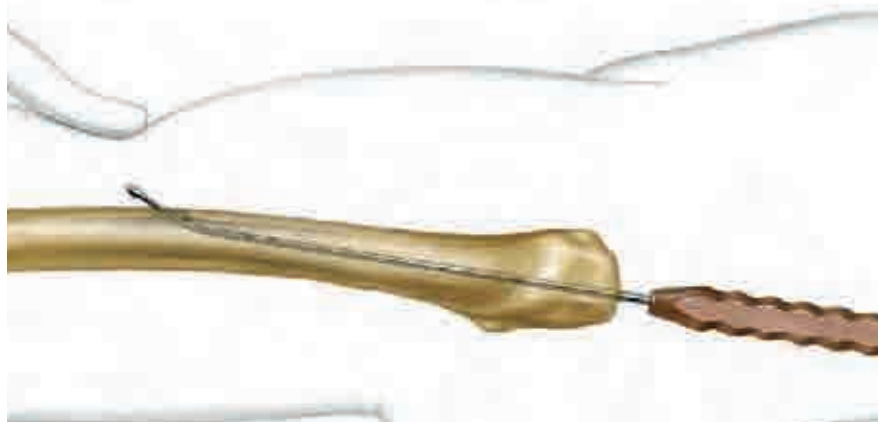

15-1170 Special mallet*,
with linen phenolic handle and safety clamps,
400 g, 270 mm



15-1042 Mallet*,
linen phenolic, lead-filled, with support rings,
Ø 45 mm diameter, 350 g, 260 mm



130-688 Mallet*,
Ø 30 and 42 mm, 530 g, 240 mm



64-4200/14 Parallel grip pliers*,
double action, 185 mm.



1:1



1:1

*not included in instrument set

■ Additional Instruments

Cement rongeur*

heavy-duty pattern, 8 x 17 mm cup-shaped jaws have deep serrations at distal ends, shaft length 300 mm

| Item no. | Version |
|----------|-----------------------|
| 130-745 | straight |
| 130-746 | angulated 30° upwards |
| 130-747 | angulated 60° upwards |

The different cement rongeurs are used to remove cement remnants from the medullary canal. Stable construction and frontal serration of the rongeurs' jaws allow powerful manipulations so that even firmly fixed islets of bone cement can be removed.

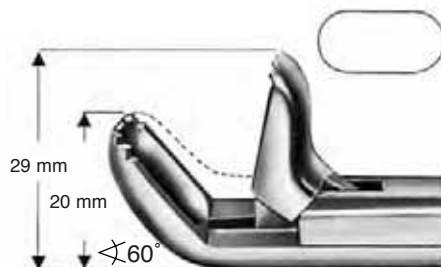
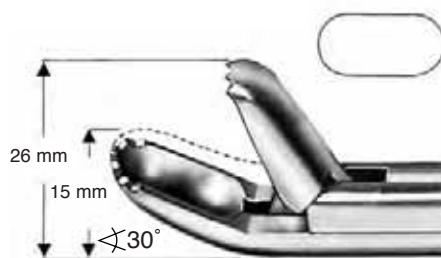
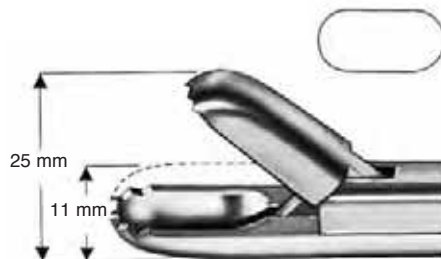

10-1727 Pliers* with tapered jaws, 200 mm

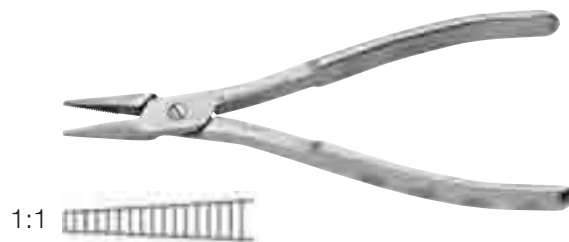

10-1728 Pliers* with rounded jaws, 200 mm

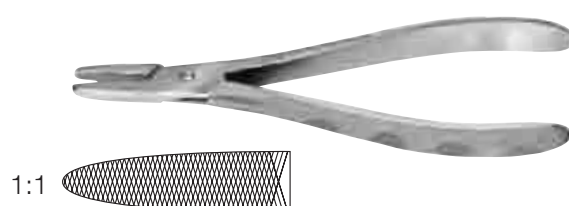

64-4200/32 Wire tightener/twister*, for wire of Ø up to 1.6 mm, 280 mm

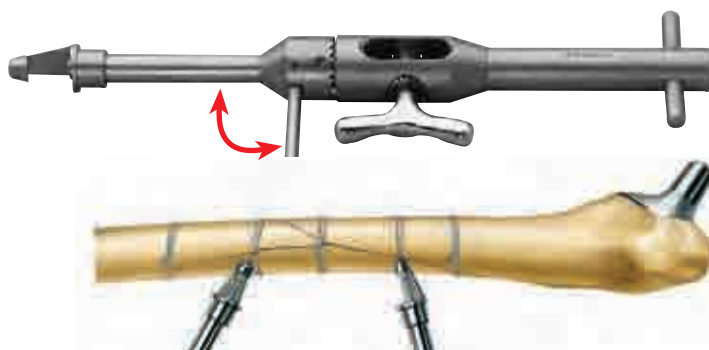

130-752/24 Universal power grip pliers*, small, with long jaws 5 x 60 mm, 240 mm



*not included in instrument set

■ Additional Instruments

130-752/30 Universal power grip pliers*,
large, with long jaws 7 x 80 mm, 300 mm

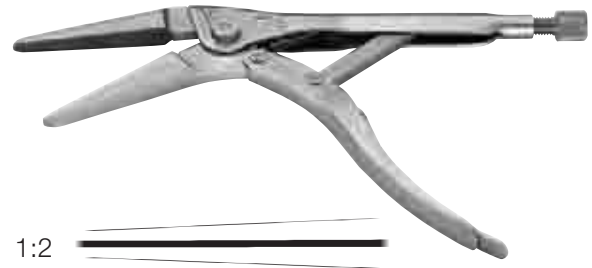

130-753/20 Universal power grip pliers*,
small, with pipe-wrench jaws 9 mm wide, 200 mm

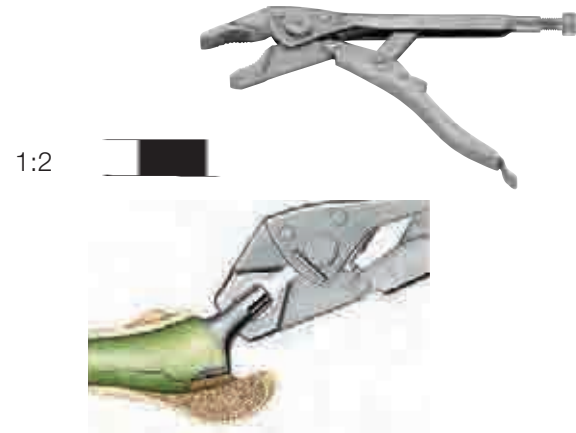

130-753/25 Universal power grip pliers*,
large, with pipe-wrench jaws 13 mm wide, 250 mm

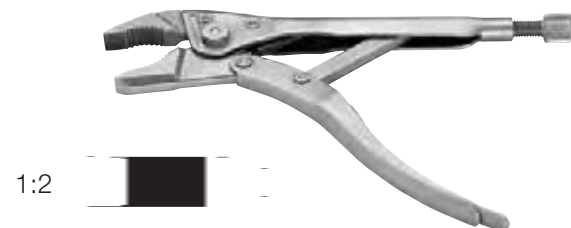

15-1436/12 Stem

15-1436/13 Handle

15-1436/14 Slaphammer

for universal power grip pliers

The different types of universal power grip pliers are used to grip and hold implant fragments for extraction. These pliers have a very strong joint region as a result of the ridges in the shanks just below the jaws and the large flat joint screws. The internal thread of the adjustment screw can be used to attach the slaphammer to the pliers.

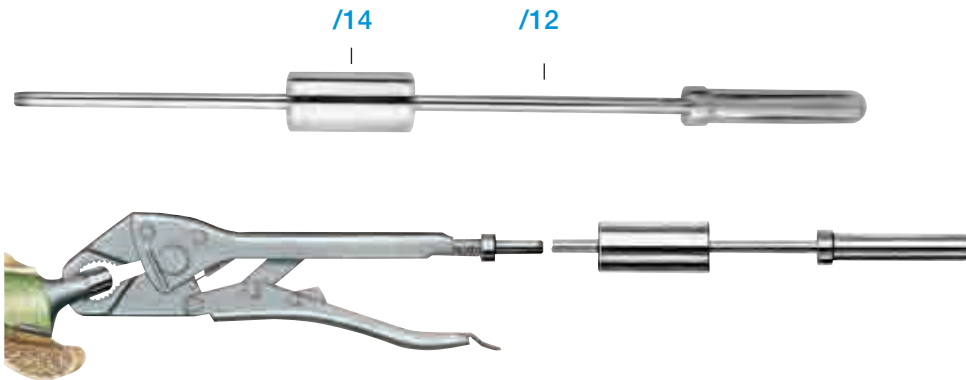

15-1024 Hohmann Retractor Model St. Georg™*,
30 mm wide, 200 mm, for universal power grip pliers

The cartilage scissors are used to dissect the vastus and gluteal tendon attachments, soft tissues and ventral capsule.

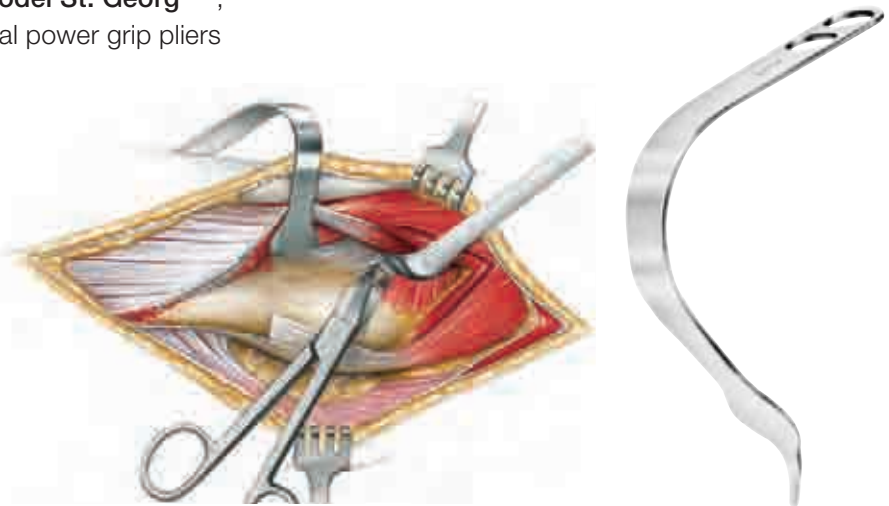

Cartilage scissors*

| Item no. | Version | Length mm |
|----------------|----------|-----------|
| 50-2562 | straight | 220 |
| 50-2564 | curved | 220 |



*not included in instrument set

■ Additional Instruments

15-1040 Lexer gouge*,
modified, bayonet-shaped, 30 mm wide, 230 mm



15-1041 Lexer gouge*,
modified, bayonet-shaped, 45 mm wide, 275 mm

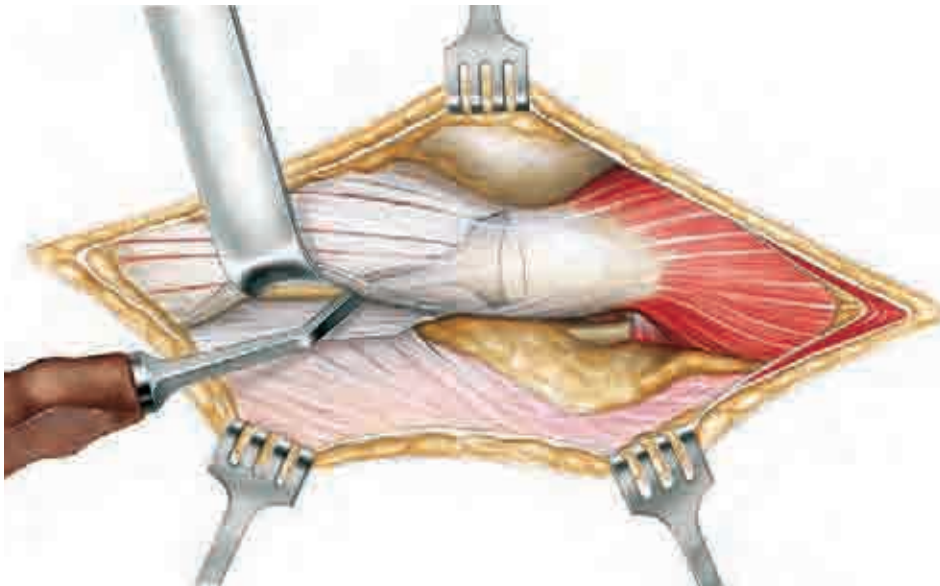

The bayonet-shaped lexer gouges are primarily used to detach the trochanter attachments of the gluteal tendon. This trochanteric approach protects the soft tissues between greater trochanter and vastus lateralis.

*not included in instrument set

■ Tip Guards

Tip Guards, protective covers, autoclavable, for cutting edges of instruments.



| Item no. | Size | Color |
|------------|------|--------|
| 10-2285/01 | 1 | Black |
| 10-2285/02 | 2 | Brown |
| 10-2285/03 | 3 | Orange |
| 10-2285/04 | 4 | Violet |
| 10-2285/05 | 5 | Yellow |
| 10-2285/06 | 6 | Red |
| 10-2285/07 | 7 | Green |
| 10-2285/08 | 8 | Blue |
| 10-2285/09 | 9 | White |

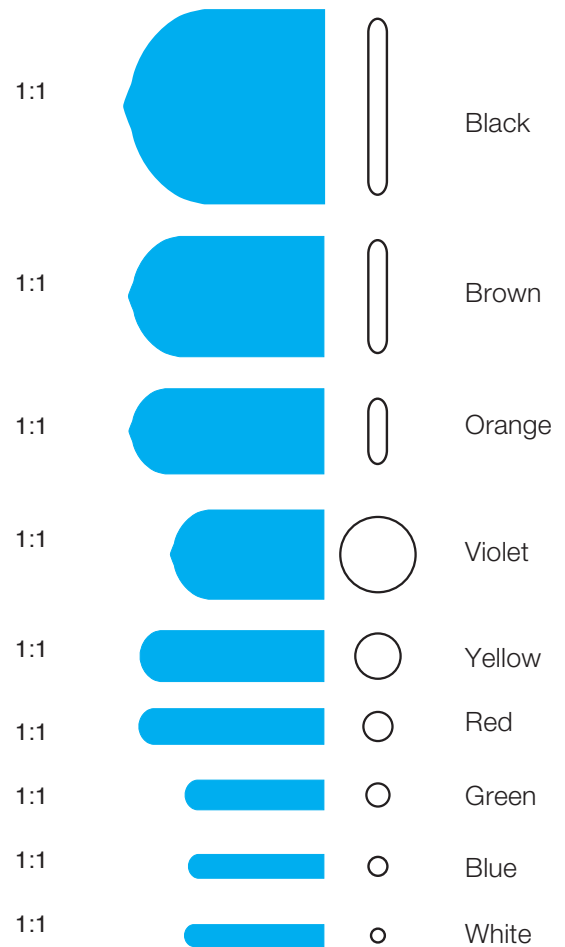

10-2285/20 Tip Guards, assorted, 100 per package



■ Accessories

■ Instrument Systems for Hip Surgery

MP® Reconstruction Prosthesis

644 en Implants/Instruments

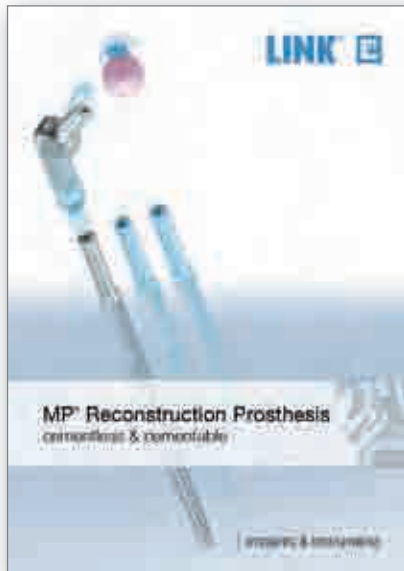

MP® Reconstruction Prosthesis

664 en Surgical Technique



Endo-Model® Saddle Prosthesis

655 dt-en

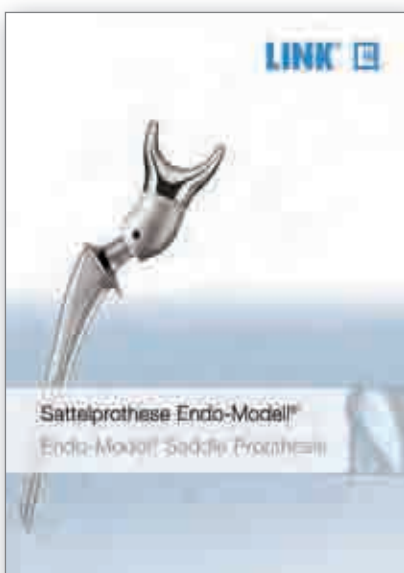

MEGASYSTEM-C®

909 en Implants/Instruments



Partial Pelvis Replacement

Endo-Model®, 661 dt-en



Instructions for Cleaning and Maintenance

Specific instructions for individual instruments are available on request from customer@linkhh.de

■ Index

| | page | | page |
|--------------------------------|--------|---------------------------------------|--------|
| 05-2003/01 | 02 | 130-642, 130-648 | 05, 07 |
| 10-1727 | 22 | 130-654 to 130-658 | 04, 09 |
| 10-1728 | 22 | 130-662 to 130-670 | 05, 09 |
| 10-2285/01 to 10-2285/09 | 26 | 130-676, 130-678 | 04, 09 |
| 10-2285/20 | 26 | 130-680 to 130-684 | 04, 10 |
| 15-1024 | 24 | 130-690 to 130-694 | 14 |
| 15-1137 | 05, 13 | 130-686 | 04, 10 |
| 15-1040 | 25 | 130-688 | 20 |
| 15-1041 | 25 | 130-698/01 | 02 |
| 15-1042 | 20 | 130-698/02 | 02, 03 |
| 15-1150 | 19 | 130-698/04 | 02 |
| 15-1170 | 20 | 130-698/06 | 02, 05 |
| 15-1431 | 03, 12 | 130-700 to 130-704 | 15 |
| 15-1436/01 | 05 | 130-710 to 130-714 | 15 |
| 15-1436/01 to 15-1436/14 | 06 | 130-720 to 130-736 | 05, 13 |
| 15-1436/12 to 15-1436/14 | 24 | 130-744 | 04, 10 |
| 15-1440/05 to 15-1440/10 | 14 | 130-745 to 130-747 | 21 |
| 50-2562 | 24 | 130-750 | 05, 14 |
| 50-2564 | 24 | 130-752/24 | 22 |
| 64-4200/14 | 20 | 130-752/30 | 23 |
| 64-4200/32 | 22 | 130-753/20 | 23 |
| 65-1700/04 to 65-1700/25 | 16 | 130-753/25 | 23 |
| 65-1701/04, 65-1701/06 | 03, 12 | 130-775 to 130-777 | 03, 11 |
| 65-1702/04 to 65-1702/25 | 16 | 130-780 to 130-782 | 03, 11 |
| 99-0001/99 | 07 | 130-783 to 130-785 | 03, 11 |
| | | 130-786/05, 130-786/10 | 17 |
| | | 130-787/05, 130-787/10 | 17 |
| | | 130-788/01, 130-788/03 | 17 |
| | | 130-790 | 19 |
| | | 130-794 | 19 |
| | | 130-795 | 19 |
| | | 130-796/05 to 130-796/10 | 18 |
| | | 130-797/05 to 130-797/10 | 18 |

■ Important Information

Please note the following regarding the use of our implants:

1. Choosing the right implant is very important.

The size and shape of the human bone determine the size and shape of the implant and also limit the load capacity. Implants are not designed to withstand unlimited physical stress. Demands should not exceed normal functional loads.

2. Correct handling of the implant is very important.

Under no circumstances should the shape of a finished implant be altered, as this shortens its life span. Our implants must not be combined with implants from other manufacturers.

The instruments indicated in the Surgical Technique must be used to ensure safe implantation of the components.

3. Implants must not be reused.

Implants are supplied sterile and are intended for single use only. Used implants must not be reused.

4. After-treatment is also very important.

The patient must be informed of the limitations of the implant. The load capacity of an implant cannot compare with that of healthy bone!

5. Unless otherwise indicated, implants are supplied in sterile packaging.

Note the following conditions for storage of packaged implants:

- Avoid extreme or sudden changes in temperature.
- Sterile implants in their original, intact protective packaging may be stored in permanent buildings up until the "Use by" date indicated on the packaging.
- They must not be exposed to frost, dampness or direct sunlight, or mechanical damage.
- Implants may be stored in their original packaging for up to 5 years after the date of manufacture. The "Use by" date is indicated on the product label.
- Do not use an implant if the packaging is damaged.

6. Traceability is important.

Please use the documentation stickers provided to ensure traceability.

7. Further information on the material composition is available on request from the manufacturer.

Follow the instructions for use!

WALDEMAR LINK GmbH & Co. KG, Hamburg

All content in this catalog, including text, pictures and data, is protected by copyright. Every instance of use, whether in part or in whole and which is not permitted by the German Copyright Act, is subject to our prior consent. In particular, this applies to the reproduction, editing, translation, publishing, saving, processing, or passing on of content stored in databases or other electronic media and systems, in any manner or form. The information in the catalogs is solely intended to describe the products and does not constitute a guarantee.

The Surgical Technique described has been written to the best of our knowledge and belief, but it does not relieve the surgeon of his/her responsibility to duly consider the particularities of each individual case.

Unless otherwise indicated, all instruments are made of surgical stainless steel.



WALDEMAR LINK GmbH & Co. KG
Barkhausenweg 10 · 22339 Hamburg, Germany
P.O. Box 63 05 52 · 22315 Hamburg, Germany
Tel.: +49 40 53995-0 · Fax: +49 40 5386929
E-mail: info@linkhh.de · Internet: www.linkhh.de

